



MetPrep 3x™
GRINDING / POLISHING SYSTEMS

*INTUITIVE, POWERFUL & RELIABLE
SYSTEMS FOR SEMIAUTOMATIC
SAMPLE PREPARATION*

Quality Products for Metallographic Sample Preparation & Analysis

The **MetPrep 3x™** grinding and polishing machines, with **PH™** power heads, are powerful systems for semiautomatic operation, ideal for low to high volume sample preparation requirements. Two combinations provide ideal solutions that accommodate any lab, application or material.

The microprocessor-based system allows the operator to use either the manual *Input Mode* to enter parameters throughout a procedure, or the user-defined preprogrammed *Steps and Sequences Mode* to select steps in a sequence as the procedure advances.

Either standard or magnetic 8"/203 mm or 10"/254 mm platens may be used with any adhesive, non-adhesive or magnetic system disc.

Standard/magnetic platens, sample loading fixture/system, sample holders and accessories are sold separately.



MetPrep 3x™/PH-4™ System shown with optional protective shield

Item	Description
5-2650	MetPrep 3x™ / PH-3™, 100-240 V
5-2750	MetPrep 3x™ / PH-4™, 100-240 V

Grinder/Polisher Features:

- Store and recall of up to ten (10) user-programmable sequences with up to ten (10) individual steps each, including settings for platen speed, force mode, comp/contra rotation (sample holder/platen), cycle time, fluid selection, sample force (lbf or N), sample rotation speed, water rinse, soft start and force reduction
- Built-in programming and seamless integration of optional ID-5x™ fluid dispenser for automatic operation
- 7" (178 mm) color LCD touchscreen with intuitive interface to control all functions, with adjustable units (lbf/N)
- Electronic coolant control with adjustable flow control valve
- Retractable coolant nozzle that allows quick and easy sample/bowl cleaning
- Constructed with components precision machined from solid billet aluminum and stainless steel
- Molded one-piece corrosion resistant enclosure with overflow diversion to protect internal components
- Powerful, quiet 0.7 HP (535 W) Brushless DC motor that provides constant high torque output throughout the speed range
- Variable platen speed: 20 – 600 RPM (10 RPM increments)
- Variable platen jog speed: 20 – 600 RPM (10 RPM increments)
- Emergency shut-off switch
- Two (2) year warranty
- Designed and manufactured by Allied in the USA 

Touchscreen Menu Navigation



Intuitive interface optimized for productivity and function

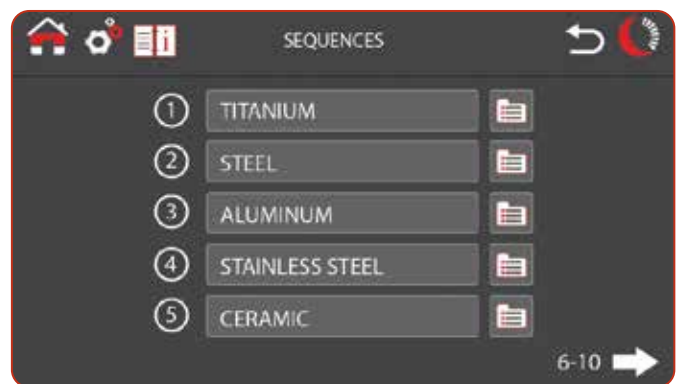

User-defined preprogrammed steps & sequences allows for quick, easy operation

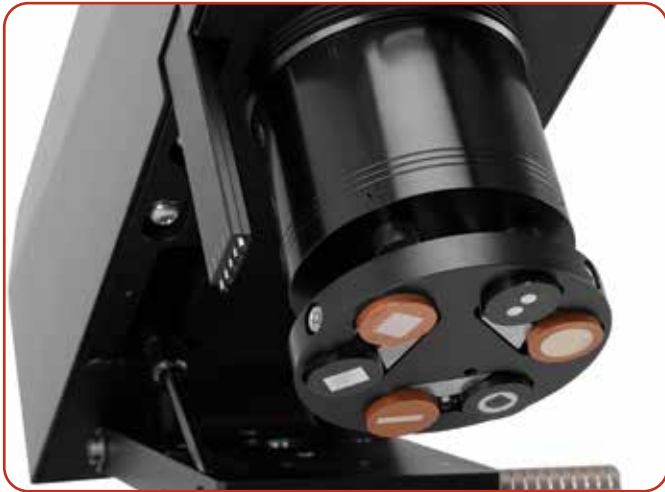

Unique tilt-up feature allows easy access to platen and holder.

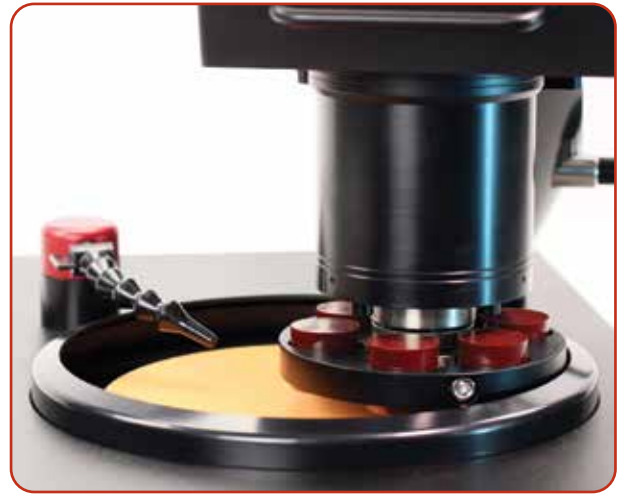

PH-3™ central force configuration: one (1) central piston applies force to up to nine (9) mounts (1.25" mounts shown).

The **PH-3™** and **PH-4™** power heads offer maximum versatility for low to high volume semiautomatic sample preparation, using either central or individual sample force modes. The pneumatic-electric systems provide controlled sample force and allow up to nine (9) samples to be prepared simultaneously, depending on power head, mount diameter and holder size. The unique tilt-up design allows easy, unhindered access to the sample holder and platen, and eliminates the need to reposition the head during the preparation procedure.

Power Head Features:

- Unique tilt-up feature for easy access to platen and holder
- Central force sample preparation of up to nine (9) samples
- Individual force sample preparation of up to four (4) samples
- 0.33 HP (250 W) motor with durable reduction gearbox for constant high torque output
- Variable sample rotation speed: 0 – 150 RPM (10 RPM increments) with comp/contra direction control
- Soft-start/stop force control
- Sample holder release button that faces the operator for easy access upon cycle completion
- Simple push-button attachment and removal of sample holders
- Safety sensor that stops operation if power head is tilted up
- Quick-lock system to allow sample holder positioning across platen radius
- Compatible with #5-33XX, #5-34XX, #5-37XX (PH-4™) and #5-38XX (PH-3™) series sample holders
- Optional #5-3X346 Protective Shield available for added safety



PH-4™ individual force configuration: four (4) individual pistons apply force to each mount (1.5" mounts shown).



Sample holder release button faces the operator for easy access upon cycle completion

Individual Force Holders

Individual force holders allow one or more samples to be prepared simultaneously. The advantage of individual preparation is that it allows removal of any number of samples from the grinding/polishing operation without affecting balance of the system. It is also ideal for applications where small geometry and site-specific cross-section requirements make alignment of more than three (3) samples to a common plane extremely challenging.

Single Diameter Mount



Mount Diameter	PH-3™ (3 position)	PH-4™ (4 position)
1" / 25 mm	5-3835	5-3735
30 mm	5-3840	5-3740
1.25"	5-3845	5-3745
1.5"	5-3850	5-3750
40 mm	5-3855	5-3755
50 mm	5-3860	5-3760
2"	5-3865	5-3765

Variable Diameter Mount

This individual force holder utilizes spacer rings for specific diameter mounts. Rings can be mixed or matched for maximum versatility.

The three (3) position (40 mm openings) and four (4) position (50 mm openings) holders are used with the PH-3™ and PH-4™ power heads, respectively. **Rings are sold separately.**



	PH-3™ (3 position)	PH-4™ (4 position)
Holder	5-3800	5-3700
1" / 25 mm Ring	5-3X35-40	5-3X35-50
30 mm Ring	5-3X40-40	5-3X40-50
1.25" Ring	5-3X45-40	5-3X45-50
1.5" Ring	5-3X50-40	5-3X50-50
40 mm Ring	-	5-3X55-50

Central Force Holders

Central force holders secure mounts/samples on a common plane. A minimum of three (3) samples must be prepared at once for balance. **Custom shapes and sizes available.**

Teardrop holders allow flexibility in the shape and size of the sample that can be held. A setscrew secures each sample.

Dual-cavity holders feature a single tightening point, which is useful for rapid insertion and removal of either one or two round or irregular shaped specimens per cavity.



140 mm Diameter, for 8" or 10" Platens

Item	Description
5-3301	Continuous Surface, for Wax or Tape, w/ Heating Stage
5-3330	(6) 25 mm - 1.25" Samples, Teardrop
5-3340	(5) 25 - 40 mm Samples, Teardrop
5-3345	(3) 25 - 40 mm Samples, Teardrop
5-3361	(6) 25 mm - 1.25" Samples, Dual-Cavity
5-3380	Sample Loading/Unloading Fixture, for 5-33XX Series

160 mm Diameter, for 10" Platens

Item	Description
5-3401	Continuous Surface, for Wax or Tape, w/ Heating Stage
5-3435	(6) 25 mm - 1.5" Samples, Teardrop
5-3440	(3) 25 mm - 2" Samples, Teardrop
5-3445	(9) 25 mm - 1.25" Samples, Teardrop
5-3460	(8) 25 mm - 1.25" Samples, Dual-Cavity
5-3461	(6) 30 - 40 mm Samples, Dual-Cavity
5-3466	(3) 1.25" x 2" (32 x 51 mm) Capacity, Clamp Style
5-3490	(5) 1.2" x 2.1" (30 x 53 mm) Rectangles
5-3491	(3) 1.6" x 2.7" (40 x 68 mm) Rectangles
5-3494	(3) 2" x 2" (51 x 51 mm) Squares
5-3480	Sample Loading/Unloading Fixture, for 5-34XX Series

Standard/Magnetic Platens

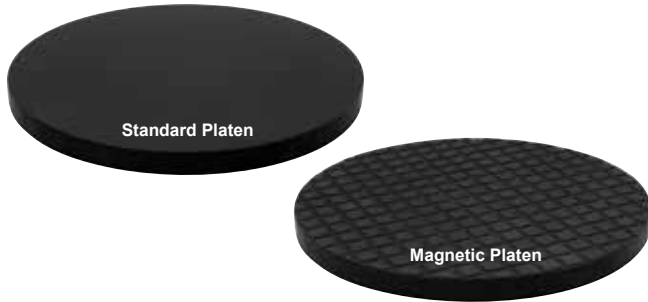

Standard aluminum platens are precision lapped parallel, then hard anodized for maximum wear resistance. They are used with adhesive backed discs, double sided adhesive discs and a combination of non-adhesive discs and paper holding bands.

Magnetic platens combine a standard aluminum platen with a cross-hatched magnetic surface for maximum flatness and adherence. Only one platen is needed throughout the grinding and polishing process, allowing all magnetic system cloths/abrasive discs or ferromagnetic discs to be utilized.

Standard	Diameter	Magnetic
5-2005	8" (203 mm)	5-2005M
5-6010	10" (254 mm)	5-6010M

Platen Storage Cabinet



This durable aluminum cabinet accommodates up to 10 aluminum trays/shelves (reversible) for storage of platens, discs or cloths up to 12" (305 mm) diameter. The hinged, clear plastic door with magnetic lock prevents dust contamination. Five (5) trays are included.

Item	Description
5-8100	Platen Storage Cabinet
5-8105	Aluminum Tray / Shelf

Recirculating System



The recirculating filtration system allows up to 3-stage filtering down to 2 microns and is housed in a durable cabinet that supports Allied grinding/polishing machines. The environmentally friendly filtration system saves up to 1/2 gallon of water per minute with quick-change filters. System includes cabinet/stand, roll-out reservoir with 7-gallon (26.5 L) capacity and pull-out storage drawer.

Item	Description
100-40020	Recirculating Filtration System, with Grinder/Polisher Control

CF-1™ System



The CF-1™ is a loading and unloading system for central force sample holders. The rotating base sets uniform mount protrusion to 3 mm and allows quick, easy positioning beneath the pad. Pneumatics are used to secure both the holder and sample/mount(s) when loading to establish a uniform plane, reducing initial grinding time and operator fatigue. Single pad attachment is included.

Item	Description
5-CF00	CF-1™ Central Force Sample Holder Loading/Unloading System
5-CF05	Single Pad Attachment for Teardrop Fixtures
5-CF10	Dual Pad Attachment for Dual Cavity & Large Mount Fixtures

ID-5x™ Fluid Dispenser

The **ID-5x™** fluid dispenser provides automatic, unattended application of abrasive polishing solutions and lubricants. This five (5) position dispenser connects to the back of the MetPrep 3x™, and is controlled and programmed through the touchscreen. Positions 4 and 5 feature high-speed pumps for dispensing colloidal solutions, and a magnetic stirring function for use with polishing slurries that normally settle.

The dispenser features a pivoting manifold mounted on the powerhead to position the dispensing nozzles so liquids clear the sample holder.



ID-5x™ Integrated Fluid Dispenser

Features:

- Five (5) dispensing positions, 16 oz. (500 mL) capacity
- Dispenses fluids based on operator's input values (pulses/minute, pulse length)
- Provides repeatable fluid dispensing for consistent results
- Integrates with MetPrep 3x™ equipped with either PH-3™ or PH-4™ powerhead
- In-cycle priming that allows temporary "full rate" dispensing during use
- Pre-dosing function provides option to "charge" the cloth at the beginning of each cycle
- Pump reverse after cycle to prevent dripping/contamination
- Positions 4 and 5 offer:
 - High speed pumps for oxide polishing
 - Rinse/flush function to eliminate clogging when using oxide solutions
 - Magnetic stirring for use with non-suspended abrasives
- Pulse duration: 0.5 – 6 seconds, 0.1 second increments
- Pulse frequency: 1 – 10 per minute
- 24 V DC power provided by grinder/polisher
- Dims: 8" W x 25" D x 9" H (203 x 635 x 229 mm)
- Two (2) year warranty
- Designed & manufactured by Allied in the USA 



ID-5x™ dispensing nozzles in a pivoting manifold

Item	Description
5-7125	ID-5x™ Integrated Fluid Dispenser

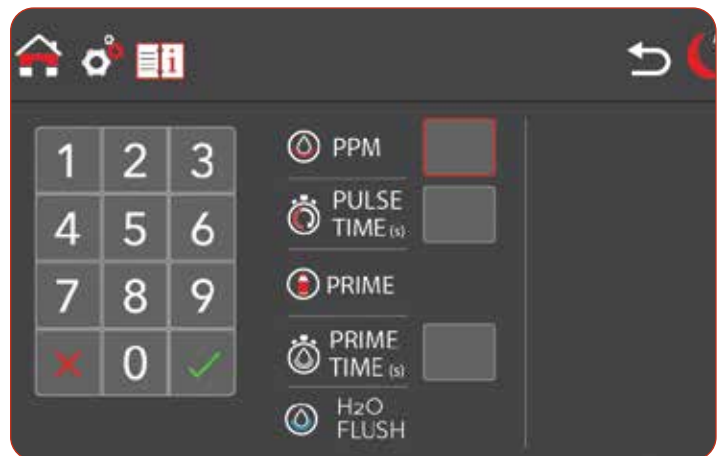

Intuitive programming of all parameters

Dimensions

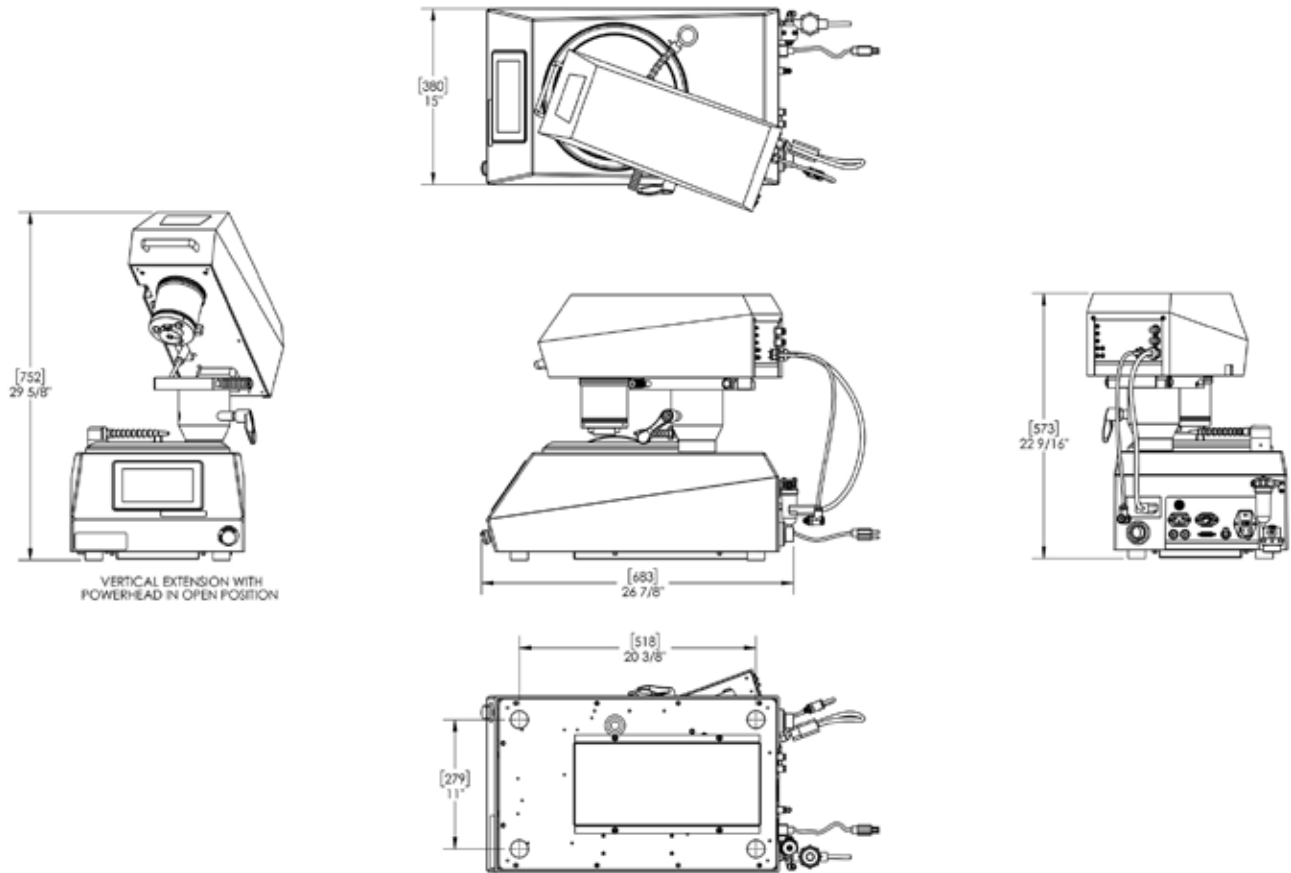

Grinder/Polisher Specifications	
Voltage	100 – 240
Platen/Jog RPM	20 – 600
Power (HP)	0.7
Power (W)	535
Cycle Time	0:05 seconds – 180 minutes
Electronics	Microprocessor-based
Display	7" LCD touchscreen - imperial or metric units
Safety	Electronic sensor on powerhead Emergency stop on polisher
Weight (PH-3/PH-4)	122/125 lbs. (55/57 kg)

Power Head Specifications		
	PH-3™	PH-4™
RPM	0 – 150	
Power (HP)	0.33	
Power (W)	250	
	Individual Force	
No. of Samples	1 – 3	1 – 4
Force (Lbf)	0 – 16	0 – 12
Force (N)	0 – 70	0 – 52
Mount Size Capacity	2" (51 mm)	2" (51 mm)
	Central Force	
No. of Samples	3 – 9	3 – 9
Force (Lbf)	5 – 50	5 – 50
Force (N)	22 – 220	22 – 220

Global Distribution of the World's Finest Products



Brochure #: MP3x V1.0

Equipment is subject to change due to innovations/improvements at any time.



Allied Equipment and Fixtures are
Designed and Manufactured by
Allied in the U.S.A.

ALLIED
HIGH TECH PRODUCTS, INC.

- Cerritos, California
- Norwalk, California
- Edmond, Oklahoma

310.635.2466 Worldwide / 800.675.1118 U.S. & Canada
Visit us online! www.alliedhightech.com